

# Door Seal Kit **eNoise Control**

297 North 9th Street, Noblesville, IN 46060  
Toll Free Phone: 888.213.4711 Fax: 317.774.1911  
[eNoiseControl.com](http://eNoiseControl.com)

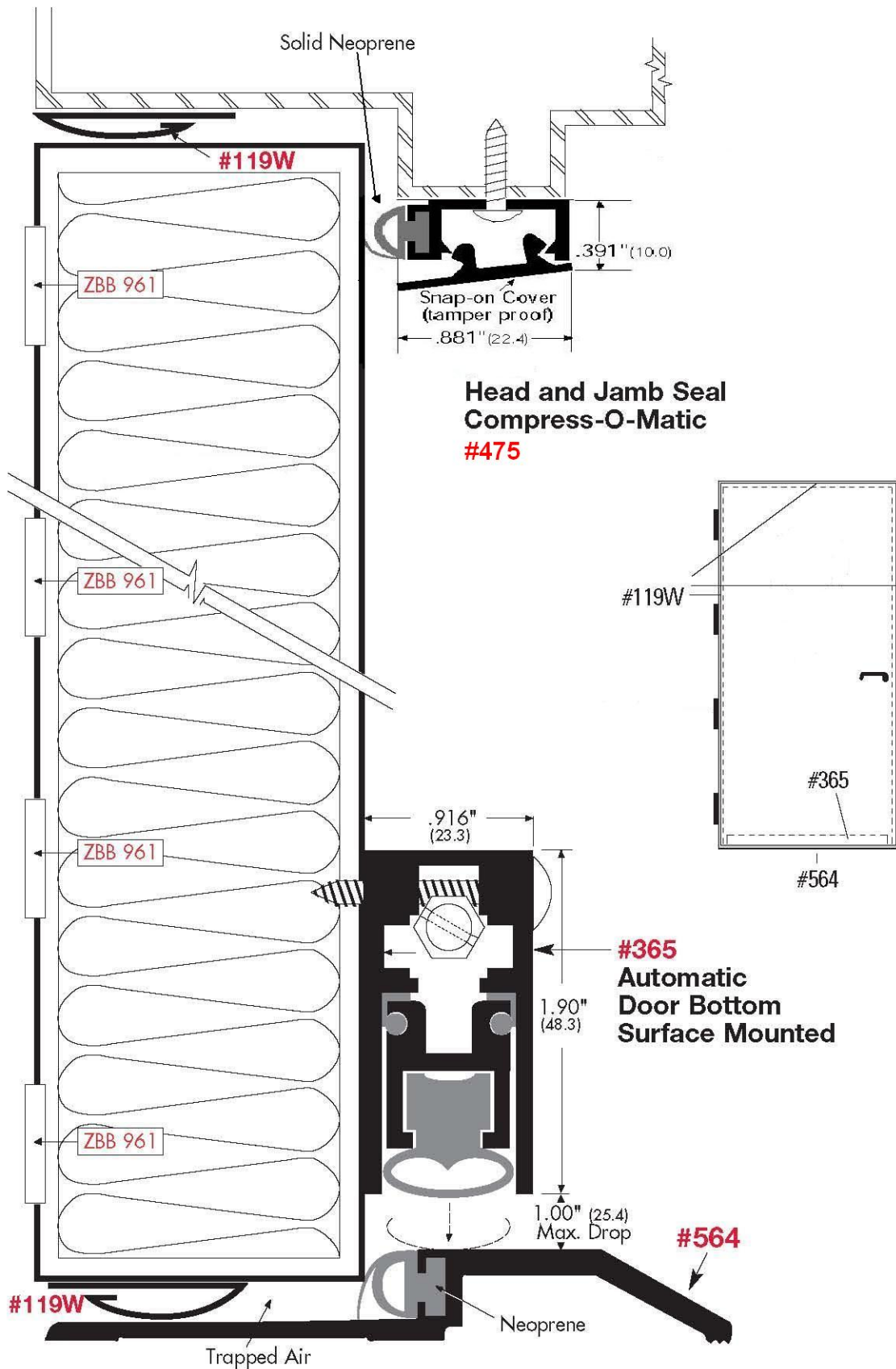

## Model #475

Head and jam seal model #475 incorporates a solid neoprene bulb with an extra “finger” that helps compensate for misalignment in the door. As the finger compresses against the rubber bulb, it is also compressed by the door itself. Tamper-proof design featuring a snap-on cover protects the gasket from impact.

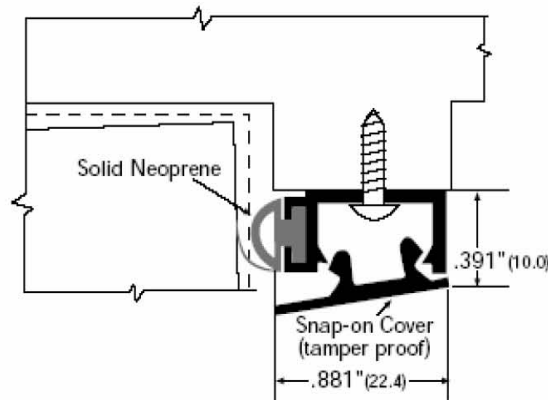

## Saddles

To achieve the highest sound ratings, our automatic door bottoms should be combined with sound-rated saddles.

## Model #566

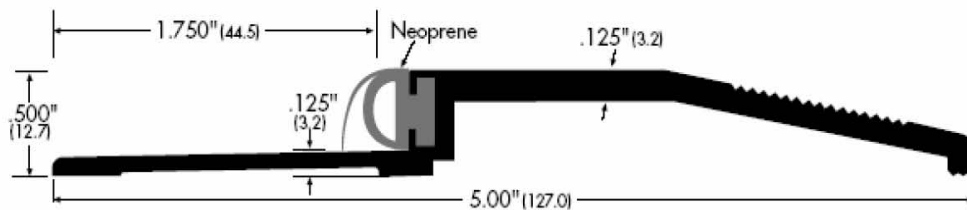

This saddle has a one-half inch rise, allowing a 1/8 inch clearance under the door. Similar to the #564, it is a good option for those who prefer the more aesthetic look of a wider ramp.

## Automatic Door Bottoms



297 North 9th Street, Noblesville, IN 46060  
Toll Free Phone: 888.213.4711 Fax: 317.774.1911  
[eNoiseControl.com](http://eNoiseControl.com)

The advanced technology common to all of our automatic door bottoms utilizes a concealed flat spring mechanism, which activates when the door is closed, lowering a neoprene seal insert firmly against the floor or saddle. Triggered by a protruding, hinge-side "plunger" that is compressed by the frame as the door closes, the spring activates, dropping the seal in a patented scissor-like motion from the hinge side and adjusting to the floor from a pivoting point. This motion ensures a smooth drop without drag and a tight seal, even on an uneven floor. As the neoprene seal compresses, it forms a tight, secure bond against the saddle or floor. The seal retracts automatically as the door is opened.



**These door bottoms have been tested through 5 million cycles. We designed and built them to last.**

---

### Model #365

---

The compression seal in this door bottom is a neoprene bulb. This model can be surface mounted. For semi-mortised installation, model #366 is available.

